

# Particulate-Hygro-Thermo-Baro Sensor Compact

## Instruction for Use

1.1007.54.78x

At start of software version V3.13



Dok. No. 022032/05/23

THE WORLD OF WEATHER DATA

### Safety Instructions

- Before operating with or at the device/product, read through the operating instructions. This manual contains instructions which should be followed on mounting, start-up, and operation. A non-observance might cause:
  - failure of important functions
  - endangerment of persons by electrical or mechanical effect
  - damage to objects
- Mounting, electrical connection and wiring of the device/product must be carried out only by a qualified technician who is familiar with and observes the engineering regulations, provisions and standards applicable in each case.
- Repairs and maintenance may only be carried out by trained staff or **Adolf Thies GmbH & Co. KG**. Only components and spare parts supplied and/or recommended by **Adolf Thies GmbH & Co. KG** should be used for repairs.
- Electrical devices/products must be mounted and wired only in a voltage-free state.
- **Adolf Thies GmbH & Co KG** guarantees proper functioning of the device/products provided that no modifications have been made to the mechanics, electronics or software, and that the following points are observed:
- All information, warnings and instructions for use included in these operating instructions must be taken into account and observed as this is essential to ensure trouble-free operation and a safe condition of the measuring system / device / product.
- The device / product is designed for a specific application as described in these operating instructions.
- The device / product should be operated with the accessories and consumables supplied and/or recommended by **Adolf Thies GmbH & Co KG** .
- Recommendation: As it is possible that each measuring system / device / product may, under certain conditions, and in rare cases, may also output erroneous measuring values, it is recommended using redundant systems with plausibility checks for **security-relevant applications**.

### Environment

- As a longstanding manufacturer of sensors Adolf Thies GmbH & Co KG is committed to the objectives of environmental protection and is therefore willing to take back all supplied products governed by the provisions of "ElektroG" (German Electrical and Electronic Equipment Act) and to perform environmentally compatible disposal and recycling. We are prepared to take back all Thies products concerned free of charge if returned to Thies by our customers carriage-paid.
- Make sure you retain packaging for storage or transport of products. Should packaging however no longer be required, please arrange for recycling as the packaging materials are designed to be recycled.



### Documentation

- © Copyright **Adolf Thies GmbH & Co KG**, Göttingen / Germany
- Although these operating instructions have been drawn up with due care, **Adolf Thies GmbH & Co KG** can accept no liability whatsoever for any technical and Typeographical errors or omissions in this document that might remain.
- We can accept no liability whatsoever for any losses arising from the information contained in this document.
- Subject to modification in terms of content.
- The device / product should not be passed on without the/these operating instructions.

## Table of contents

1	Models .....	4
2	Application .....	5
3	Setup and Mode of Operation .....	5
4	Measurements at high humidity and fog.....	6
5	Recommendation Side Selection / Standard Installation .....	7
6	Electrical Installation .....	8
6.1	Connection of the measurement electronics .....	8
6.1.1	Connection Diagram .....	9
6.1.2	Plug Assignment .....	9
6.1.3	Cable for the measurement electronics .....	10
6.1.4	Plug and Cable Mounting .....	11
6.1.5	Connection of ventilation .....	12
6.1.6	Cable assignment .....	12
6.1.7	Fan status .....	12
7	Maintenance .....	13
8	Firmware Update .....	13
9	Bootloader .....	14
10	Interface.....	14
10.1	Command Interpreter THIES .....	15
10.1.1	Telegram Formats.....	17
10.1.2	Generation Check Sum:.....	17
10.1.3	Status Information:.....	18
10.2	Commands and Description .....	18
10.2.1	Command BR .....	19
10.2.2	Command CF .....	19
10.2.3	Command CI.....	20
10.2.4	Command EDC.....	20
10.2.5	Command EFS .....	21
10.2.6	Command FB.....	24
10.2.7	Command HW .....	24
10.2.8	Command ID.....	25
10.2.9	Command KY .....	25
10.2.10	Command LL .....	26
10.2.11	Command OR.....	26
10.2.12	Command PO .....	27
10.2.13	Command RD .....	27
10.2.14	Command RS .....	28
10.2.15	Command SF.....	29
10.2.16	Command SH .....	29
10.2.17	Command SN .....	30
10.2.18	Command TA.....	30
10.2.19	Command TR .....	31
10.2.20	Command TT .....	31
10.3	Command Interpreter MODBUS RTU .....	32
10.3.1	Measured Values (Input Register).....	33
10.3.2	Commands (Holding Register) .....	35
11	Data Telegrams .....	36

11.1	Telegram 1 .....	36
11.2	Telegram 2 .....	37
11.3	Telegram 3 .....	38
11.4	Telegram 4 .....	39
11.5	Telegram 5 .....	40
11.6	Telegram 6 .....	41
12	Technical Data .....	42
13	Dimensional Drawing .....	44
14	Accessories (optional).....	45
15	Appendix.....	46
15.1	Calibration of the Sensor .....	46
15.2	Calibration of Temperature / Humidity .....	46
15.3	Calibration of Air Pressure.....	46
15.4	Table and Figures Overview .....	47
16	EC-Declaration of Conformity .....	48
17	UK-CA-Declaration of Conformity .....	49
18	More Information / Documents as download .....	50

[The list of tables and figures can be found in the appendix.](#)

## 1 Models

Order no.	Serial interface / Data format / Analogue Output	Supply	Model with
1.1007.54.780	RS 485 HD / THIES ASCII / -	2 x 12 ... 30V DC	Measuring electronics with plug, weather and radiation protection with permanently connected 5m cable.
1.1007.54.781	RS 485 HD / MODBUS RTU / -	2 x 12 ... 30V DC	

The following parts are included in the scope of delivery:

- 1 x Particulate-hygro-thermo-baro sensor compact
- 1 x Mating connector for cable assembly
- 1 x Instructions for use short version (included in the package)
- 1 x Factory setting (included in the package)

The inductions for use for the Particulate-Hygro-Thermo-Baro Sensor Compact are available for download under the following link:

[https://www.thiesclima.com/db/dnl/1.1007.54.78x\\_Part particulate\\_Hygro\\_Thermo\\_Baro\\_Compact\\_eng.pdf](https://www.thiesclima.com/db/dnl/1.1007.54.78x_Part particulate_Hygro_Thermo_Baro_Compact_eng.pdf)

## 2 Application

---

The Particulate-hygro-thermo-baro sensors from our COMPACT series are designed to measure relative humidity, air temperature and barometric air pressure, and particulate matter values PM10 and PM 2.5.

The sensors are primarily intended for use in distributed particulate matter measurement outdoors. For example, the particulate matter distribution in a district can be recorded using several hygro-thermo-baro sensors. Thanks to its universal interface, the sensor can also be used as an individual solution in any suitable application.

The interface to the device is digital and consists of an RS485 interface in half duplex mode. Together with the ID-based communication, the interface allows the sensors to be operated in a bus system.

Two data protocols are available:

- ASCII (THIES format)
- Binary (MODBUS-RTU)

## 3 Setup and Mode of Operation

---

The sensor is equipped with a built-in pressure sensor, as well as a replaceable hygro-thermo module for recording the air temperature and relative humidity, as well as a replaceable particulate matter sensor. The durable sensors are adjusted and calibrated at the factory.

The hygro-thermo module is supplied with a filter cap. The module is also protected by its own white membrane. The sensor therefore achieves excellent dynamic behavior. This protective membrane must not be removed. We offer an additional filter cap for challenging environmental conditions (see 15. Accessories). A PT1000 module is used for temperature measurement.

The entire sensor system is integrated into a ventilated weather and radiation protection system which, in addition to its protective function, also ensures compliance with the specified accuracies and response times.

The individual measured values are recorded and analyzed once a second. The last measured second value is always output. The dew point and absolute humidity are calculated internally from the temperature and relative humidity. These are also output in the data telegram.

The air pressure sensor always measures the existing absolute air pressure (QFE) present at the installation site. The station height above sea level can be specified using parameter SH to calculate the corrected air pressure at sea level (QNH). This air pressure that is reduced to sea level (QNH) is the air pressure that is specified by official bodies (for example meteorological services) for a specific location.

The absolute air pressure is measured at the height of the sensor (measuring height, see drawing).

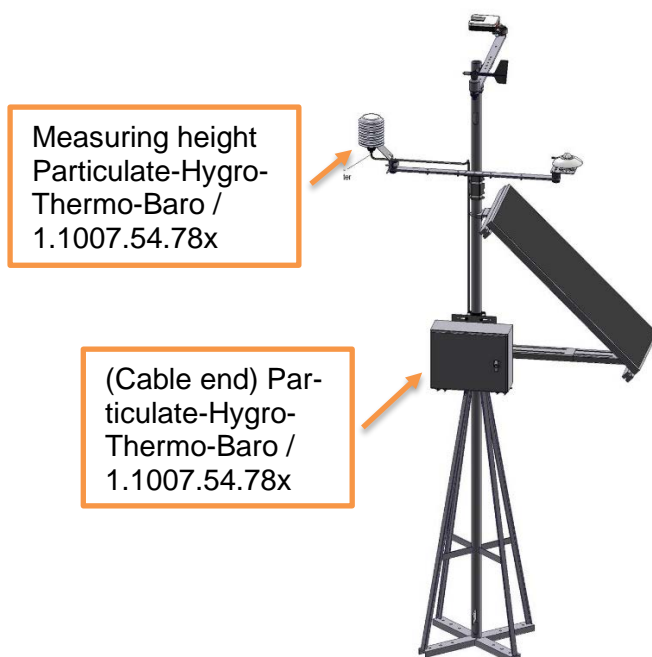

**Figure 1: Example Pressure Equalization**

The ambient air is sucked in at the lower end of the device for the particulate matter measurement. By scattering a LASER beam, the particles in the air are analyzed and the particulate matter values are determined.

## 4 Measurements at high humidity and fog

---

The particulate-hygro-thermo-baro sensor detects the particles in the air with the help of light scattering. Depending on the composition of the particles and the humidity of the air, it may be the case that particulate matter swells and is therefore measured as an enlarged particle. It is also possible that small water droplets are detected by the sensor in the case of fog.

However, official information on particulate matter values as subsequently published by state measuring bodies refers to dried particulate matter, meaning that the measured values of the particulate-hygro-thermo-baro sensor may deviate upwards.

In order to estimate the probability of a deviation due to humidity and fog, in addition to the measured values, this sensor also offers an indicator for the influence of humidity on the particulate matter values according to the following scheme:

Particulate matter measurement quality indicator	Description
4	Very high accuracy
3	High accuracy
2	Possible reduced accuracy
1	Probable accuracy
0	Undefined / Error

**Table 1: Particulate matter measurement quality indicator**

## **5 Recommendation Side Selection / Standard Installation**

---

The particulate-hygro-thermo-baro sensor must be mounted at a location that is representative for the climate measurement. For meteorological and climatological applications, this is 2m above ground with grass.

The mounting position is specified by the weather and radiation protection. The bracket is intended for mounting on mast tubes with a diameter of 35 ... 50mm.

The sensor should therefore be mounted in such a way to avoid the ingress of water.

It should also be ensured that the operating voltages are observed and that there is good air circulation around the sensor. Any deviations here may influence measured values (e.g. due to self-heating).

The measured values for temperature and humidity as well as all measured values derived from them can only deliver precise results when the fan is running properly.

## 6 Electrical Installation

The electrical installation of the particulate-hygro-thermo-baro sensor is divided into two parts. The measuring electronics are connected via a plug connection, which is used both for the power supply and for communication. The ventilation of the weather and radiation protection is connected via a cable that is firmly connected to the device.

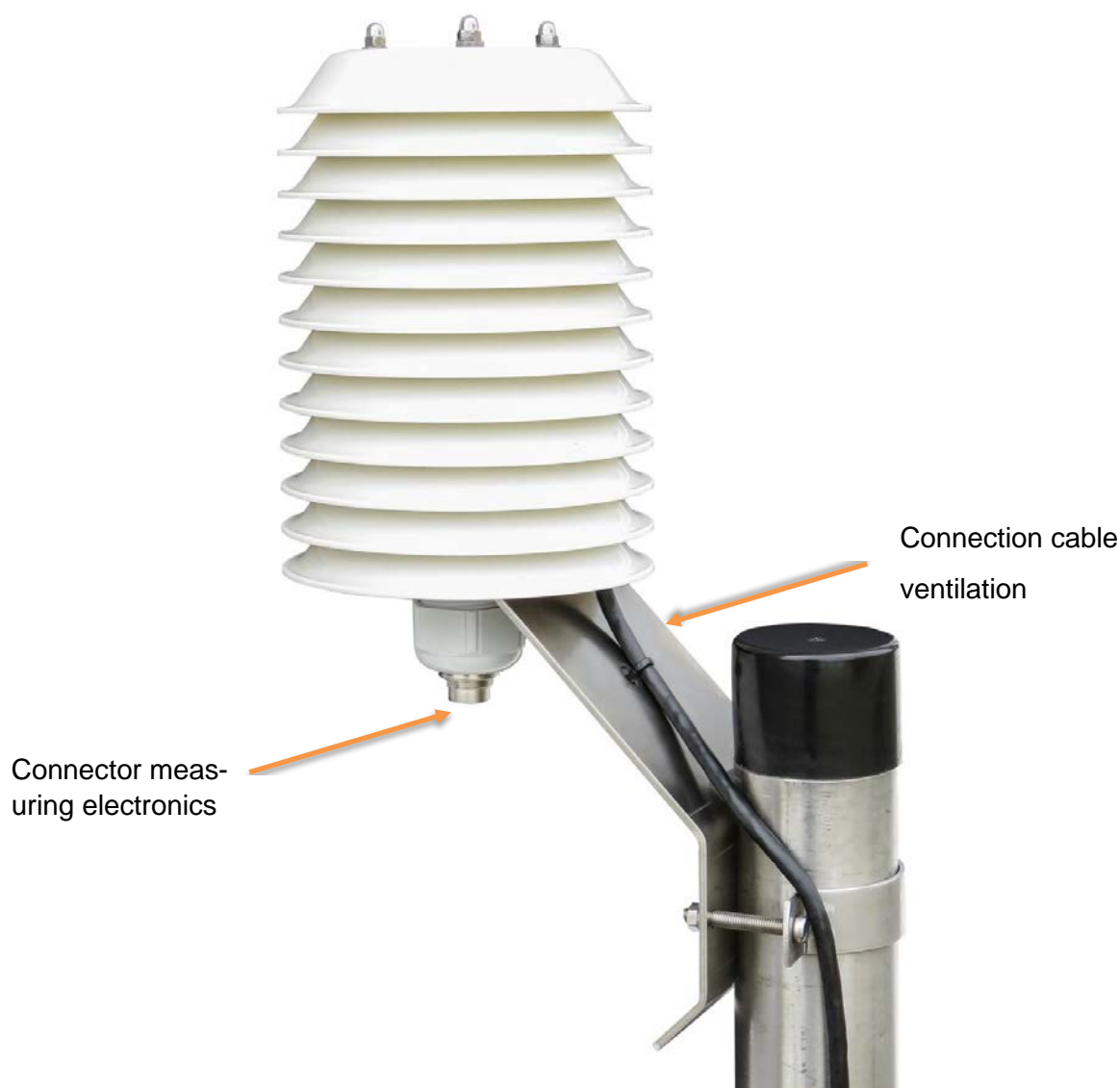

### 6.1 Connection of the measurement electronics

**Note:**

*The RS485 interface is galvanically connected to the supply voltage. The sensor internally contains 2 bias resistors each 47kOhm from RxD to +3.4V and TxD to GND.*



### 6.1.1 Connection Diagram

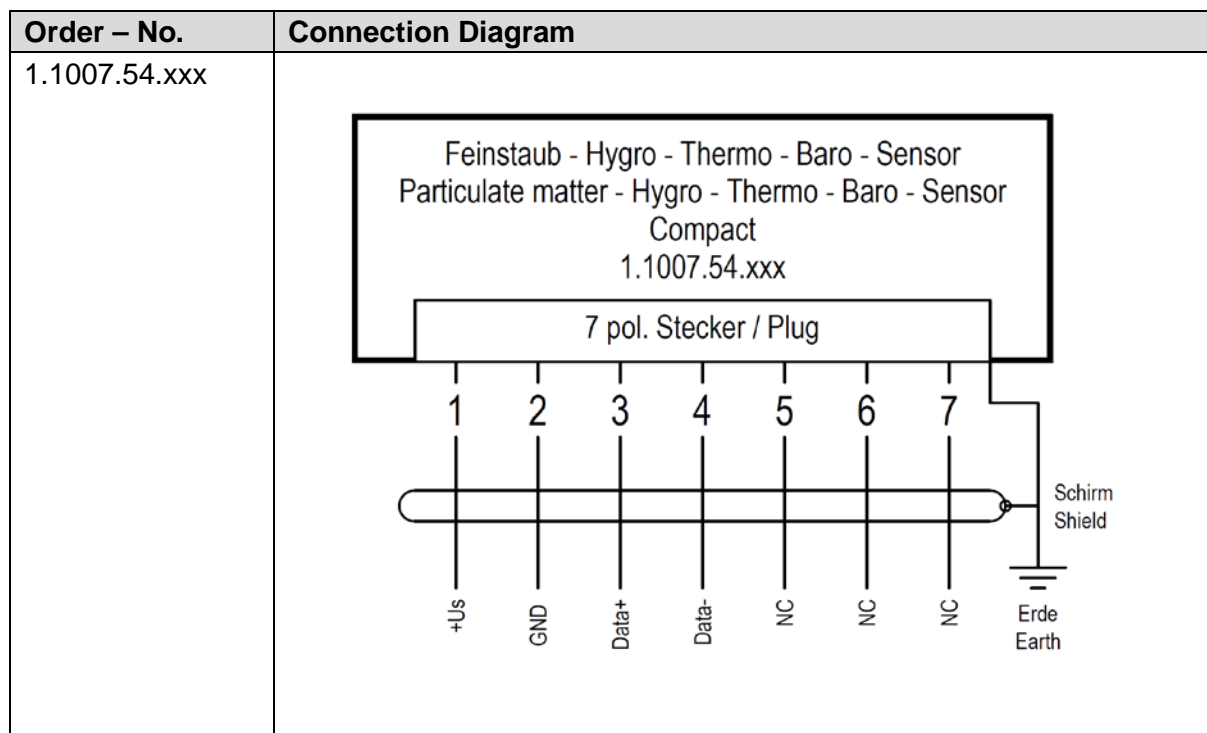

\* Outputs 1 to 3 only have a function with analogue output sensors and are configurable

### 6.1.2 Plug Assignment

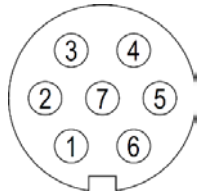
Order – No.	PIN	Name	Function	Core color <sup>1</sup>	Mating connector
1.1007.54.78x	1	+Us	Supply voltage	white	View on the soldered joint of the counter plug 
	2	GND	Ground	brown	
	3	Data+	RS485 Data + (A)	green	
	4	Data-	RS485 Data – (B)	yellow	
	5	NC	Not connected	gray	
	6	NC	Not connected	rose	
	7	NC	Not connected	blue	
	⏏	Shield	-	green – yellow	

**Table 2: Plug assignment of the sensor 1.1007.54.78x**

<sup>1</sup> with cable assembly from Thies Clima (accessories). Depending on the variant, the unused cores may not be available

### 6.1.3 Cable for the measurement electronics

The cable to be connected should have the following properties: 4 cores, core cross-section 0.25mm<sup>2</sup>, cable diameter 3 ... 5mm, resistant to ultraviolet rays, overall shielding.

The following procedure is recommended for using the cable shield:

Lay the cable shield between the sensor and the data acquisition system (e.g., datalogger) on both sides. Ground the data acquisition system.

## 6.1.4 Plug and Cable Mounting

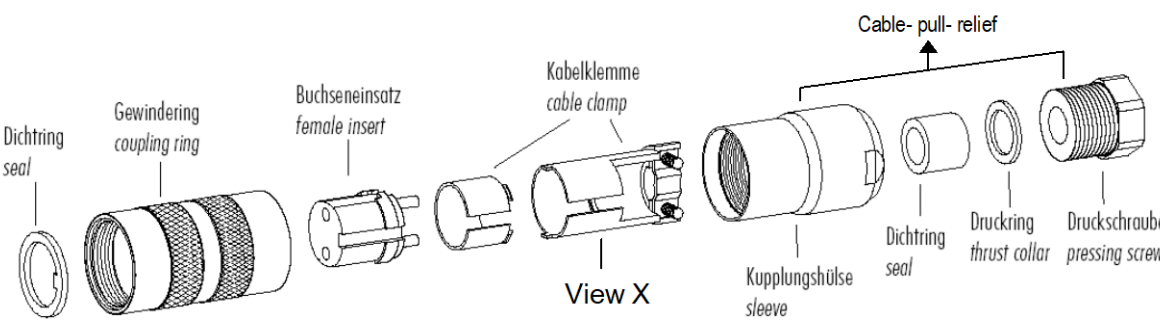
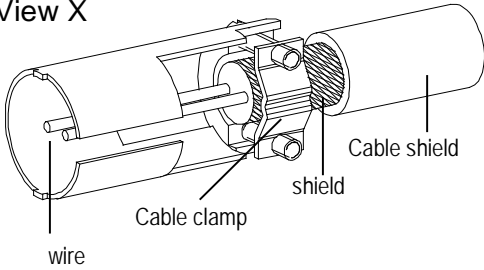
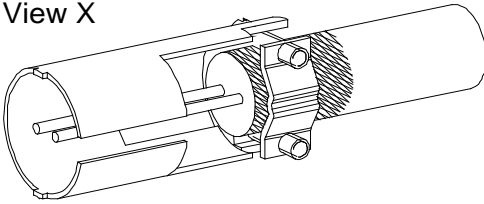
Coupling socket, Type: Binder, Serial 423, EMC with cable clamp	
	
Cable connection: <b>with</b> cable shield	
<ol style="list-style-type: none"> <li>Stringing parts on cable acc. to plan given above.</li> <li>Stripping cable sheath 20mm Cutting uncovered shield 15mm Stripping wire 5mm.</li> </ol> <p><i>Cable mounting 1</i> Putting shrink hose or insulating tape between wire and shield.</p> <p><i>Cable mounting 2</i> If cable diameter permits, put the shield backward on the cable sheath.</p> <ol style="list-style-type: none"> <li>Soldering wire to the insert, positioning shield in cable clamp.</li> <li>Screwing-on cable clamp.</li> <li>Assembling remaining parts acc. to upper plan.</li> <li>Tightening pull-relief of cable by screw-wrench (SW16 und 17).</li> </ol>	<p><i>Cable mounting 1</i> View X</p>  <p><i>Cable mounting 2</i> View X</p> 

## 6.1.5 Connection of ventilation

### 6.1.6 Cable assignment

The permanently connected cable for the ventilation is assigned as follows:

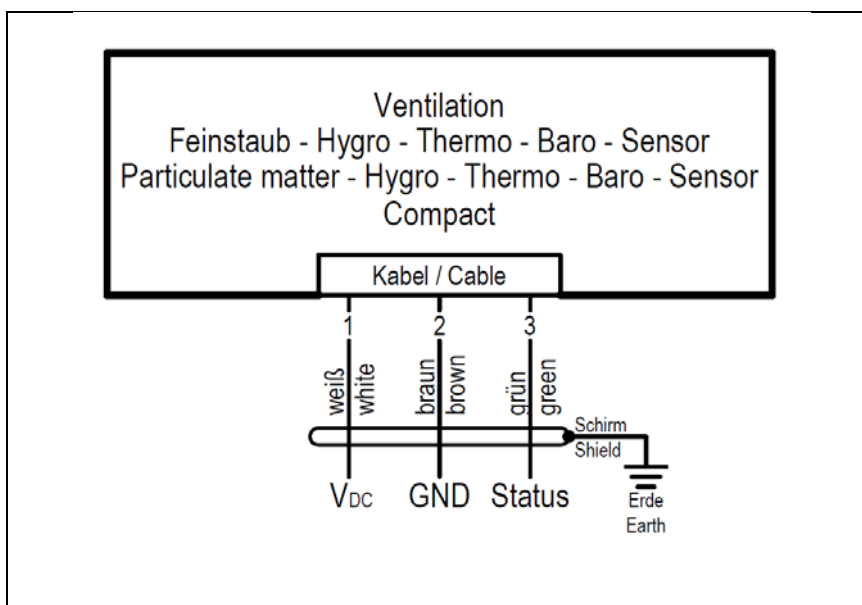

Figure 2: Ventilation connection diagram

### 6.1.7 Fan status

The status output signals the status of the fan. A high signal indicates that the fan is working correctly, if the output is 0V there is a malfunction.

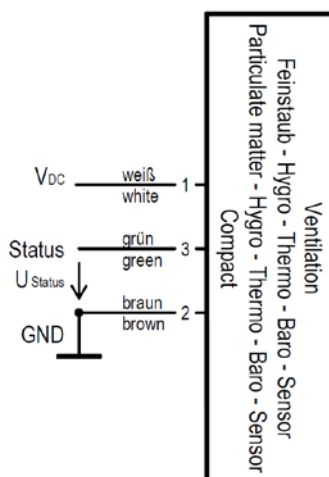

Figure 3: Connection of the status output

The voltage  $U_{\text{Status}}$  takes on following values:

Operating condition	Voltage $U_{\text{Status}}$
Normal operation	4,9 ... 5,2V
Fan spins too hard / is blocked	0,5 ... 0,6V
No supply voltage	0V

Figure 4: Ventilation status output values

## 7 Maintenance

---

The particulate-hygro-thermo-baro sensor compact is supplied adjusted and calibrated. The **PT 1000 sensor** is optimally aligned at the factory. It should not be bent any other way.

Although dust deposits do not damage the humidity sensor, they will impair dynamic behaviour. With very heavy soiling dust can be blown off the hygro-thermo sensor element or it can be carefully rinsed in distilled water.

To do this, the device must be opened by unscrewing the three cap nuts on the top. The white protective slats and the ventilation unit can then be removed one after the other until the Hygro-Thermo module is accessible. If a filter cap is used (see chapter 14 Accessories), it must be carefully pulled off upwards without bending the PT1000.

Do not touch the highly sensitive hygro-thermo sensor element on the **sensor surface**.

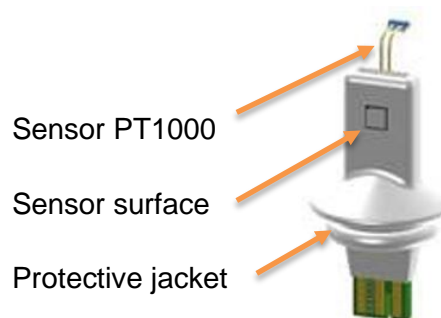

Figure 5: **Hygro-thermo Measuring Element**

The white **protective jacket** on the hygro-thermo sensor element must not be removed.

If used with a filter cap, this should also be cleaned or replaced as required. When the protective cap or filter cap has been removed, the Hygro-Thermo module can also be pulled up to clean or replace it.

After maintenance, all parts are reassembled in reverse order. Particular attention must be paid to the correct seating of the hygro-thermo module and the protective or filter cap, as these also ensure the tightness of the device.

The particulate matter sensor does not have to be serviced, but is automatically cleaned regularly. Sensor cleaning only takes place automatically when the power supply is interrupted and can also be started manually (see EDC command). During the maintenance of the particulate matter sensor, the emitted particulate matter values remain constant for about 10 seconds and a slightly increased volume may be observed on the underside of the device.

## 8 Firmware Update

---

The firmware can be updated using the program "ThiesDeviceUtility" (see also 8 Bootloader). This program can be downloaded from the THIES homepage and installed. The firmware files are directly available from Thies. Firmware updates should only be performed prior to calibration of the sensor.

## 9 Bootloader

---

The software in the device consists of 2 components:

- Bootloader
- Firmware

The program part "Bootloader" cannot be changed and is executed first whenever the device starts up. The behaviour of the bootloader depends on the parameter "FB" (Fast Boot):

### **Command: FB=0**

The bootloader waits approx. 10s for the new firmware to be received via XMODEM protocol. The character "C" is output every second. The firmware starts either after the new firmware has been received or at the end of 10s.

### **Command: FB=1**

The bootloader starts the firmware at once.

The protocol XMODEM CRC with a user data length of 128 bytes per packet is used to transfer the firmware. The interface is operated here with 9600baud, 8 data bits, no parity and a stop bit (9600, 8, N, 1).

To assist with parameter settings and / or special configurations, our free Device Utility Tool (Art. No. 9.1700.81.000) is available for download via the following link.

Link: <https://www.thiesclima.com/de/Download>

Program "Thies Device Utility" under heading "General".

## 10 Interface

---

The interface to the sensor consists of an RS485 connection (half duplex mode) with the following interface parameters<sup>2</sup>:

- 9600 baud (the baud rate can be set with **Command BR**)
- 8 data bits.
- No parity.
- 1 stop bit.
- Data in ASCII format (command interpreter: THIES).
- Data in binary format (command interpreter: MODBUS RTU).

The behaviour (configuration) of the sensor can be changed with the commands available (see **Command and Description**). With the command interpreter type THIES the measured values are queried with **Command TR**.

If the parameter FB (see **Command FB**) is set to one or zero, the telegram "LL" is output when the sensor starts.

---

<sup>2</sup> If the factory settings deviate from the settings shown here, the actual settings are noted on the "Factory settings" document supplied.

**Note:**

*The start message is output with the baudrate set (see "Command BR") and the data format 8N1 (8 data bits, no parity, 1 stop bit).*

*The sensor is equipped with a half-duplex interface. If the sensor is set to automatic telegram output, commands can only be sent to the sensor without errors within the first 60 seconds. When commands are sent during independent telegram output, communication errors can occur.*

## 10.1 Command Interpreter THIES

The sensor is equipped with the command interpreter type THIES, which can be used to change the behaviour of the device or query information. It is possible e.g., to change the station height for calculating the reduced air pressure with command "SH" or to query sensor information with the command "LL".

A command basically has the following structure:

- `<id><command><CR>` Without parameter: used to query the selected parameter
- `<id><command><parameter><CR>` With parameter: used to set a new parameter

The following placeholders have been used here:

id:	Identification number ("00" to "99")
Command:	Command consisting of 2 or 3 characters (see list of commands)
Parameter:	Parameter value with 1 to 10 places (decimal value in ASCII format directly following command without blanks)
<CR>:	Carriage return (13 <sub>dec</sub> ; 0x0D)

The identification number 'id' can be used to operate several devices together in the bus system. Here each device is assigned an individual 'id' (see **Command ID**).

When sent, a command is acknowledged with a corresponding echo telegram. The echo telegram generally begins with "!", followed by the id, the command and the value set. This is followed by the characters "carriage return" and "new line".

The standard response deviates with erroneous commands or commands relating to status queries.

Commands can be sent either with or without parameters. If no parameter is specified, the set value is output.

<i>Example:</i>	00BR<CR>	Sendebefehl ohne Parameter
	!00BR00005<CR>	Standard Echotelegramm
	00EFS<CR>	Sendebefehl ohne Parameter
	Fault status:	Echotelegramm mit Fehlermeldung Vcc zu klein
	Main board: 0001	
	Air pres.: OK	
	Dust: OK	

```

Meas. element:OK
I2C:           OK
EEPROM:       OK
SHT Humidity: OK
SHT35 Temp.:  OK
Dew point:    OK

```

If a command is sent with a parameter, the parameter is checked. If the parameter is valid, it is stored and specified in the echo telegram. If the parameter is invalid, it will be ignored and the set value output in the echo telegram. In special cases the standard echo telegram is not output with incorrect parameters, but the special telegram !00CE00008 (Incorrect key) or !00CE00016 (Parameter invalid).

*Examples:*

```

00ID00005<CR>      Transmission command.
!05ID00005<CR>      Echo telegram (Parameter valid and password OK).

00ID00004<CR>      Transmission command.
!00ID00000<CR>      Echo telegram (Parameter valid but key incorrect).

00EFS1<CR>         Transmission command.
!00CE00008<CR>      Echo telegram (Parameter valid but key incorrect)

00OL1000<CR>       Transmission command.
!00CE00008<CR>      Echo telegram (parameter incorrect but key correct).

```

**Note:**

***The measured sensor values can be queried with the command TR. Here the sensor does not respond with the echo telegram, but with the requested data telegram!***

To avoid any unintentional change in parameters, some commands (see list of commands) are protected with a password. This password must be transmitted before the actual command.

*Example: Change in baud rate*

```

00KY1<CR>          Commands releasing the user level
00BR4<CR>          Set baud rate to 4800
!00BR00004<CR>    Baud rate set to 4800

```

The sensor supports 3 different password levels:

- User level 0 (standard mode, without password)
- User level 1 (password: "1", for user parameter settings)
- Administrator level
- Calibration level for calibration laboratories



**Please note:**

**Password-protected commands are released as long as one of the following conditions is satisfied:**

- **switching of supply voltage**
- **command 00KY0<CR> is sent**
- **no new command is sent for min. 120s**

### 10.1.1 Telegram Formats

Data output takes place in response to the command TR. Selection between different telegrams is possible. Alternatively, the independent telegram output can also be activated (see commands OR and TT). Telegram 6 should be used to calibrate the sensor, since the measured variables temperature, humidity and air pressure are output with two decimal places.

Calculation of the checksum, composition of the status word and the control characters/separators used in the telegrams are described below.

#### Control characters:

CR – Carriage Return (13<sub>dec</sub>; 0x0D)

LF – Line Feed (10<sub>dec</sub>; 0x0A)

STX – Start of Text (2<sub>dec</sub>; 0x02)

ETX – End of Text (3<sub>dec</sub>; 0x03)

#### Characters:

The individual measured values in the string are separated by a semicolon ';'. The multiplication sign '\*' is used as the check sum separator.

### 10.1.2 Generation Check Sum:

The check sum is the result of bitwise EXOR linking of the bytes output in the telegram.

The EXOR link encompasses all bytes between the telegram start character "STX" and the byte "\*" as the identifying character for the start of the check sum.

The bytes "STX" and "\*" are not taken into account for calculation of the check sum. Calculation of the checksum starts with the value 0.

### 10.1.3 Status Information:

In the sensor there is a status word (32bit), which supplies information about the state of the sensor. The measured values undergo a plausibility check and are displayed in the status word, including the measured value telegrams (see command TR).

Bit number	Function	Description
Bit 0	VCC fault	The supply voltage is < 6 V or > 30V
Bit 1	3V fault	The 3V processor voltage is not OK
Bit 2	Fault pressure sensor	The pressure sensor reports fault
Bit 3	Without particulate matter sensor	No valid module was detected
Bit 4	Particulate matter sensor failure	The dust sensor reports an error
Bit 5	Reserved	Reserved
Bit 6	No hygro-thermo-measuring element	No valid hygro-thermo-measuring element was detected
Bit 7	Hygro-Thermal Sensor Error	The hygro-thermo-measuring element reports error

Table 3: Status Word

## 10.2 Commands and Description

The following table lists the available commands and the corresponding password for read and writing.

Command	Initial value Factory setting	MODBUS Register address	Description	Password	
				Read	Write
BR	96	40005	Baud rate	Without	User
CF	0	-	Calibration Status	Without	-
CI	0/1 <sup>3</sup>	40013	Command interpreter	Without	User
EDC	0	40045	Manual particulate matter sensor maintenance	Without	User
EFS	-	-	Extended error status	Without	User
FB	1	40001	Quick start	Without	User
HW	-	-	Hardware Configuration	Without	-
ID	0/1 <sup>4</sup>	40003	ID-number	Without	User
KY	0	40009	Key / Password	Without	-
LL	-	-	Inquiry of the sensor status	Without	-
OR	1000	40017	Telegram output interval	Without	User
PO	5000	40025	Air pressure offset	Without	-
RD	20	40019	Response delay	Without	User
RS	-	40021	Reset	Without	User
SF	0	40015	Frame format (RS485)	Without	User
SH	0	40023	Station height	Without	User
SN	individual	40007	Serial number	Without	-
TA	-	-	Part number	Without	-
TR	-	-	Telegram query	Without	-
TT	0	-	Automatic telegram query	Without	User

Table 4: List of commands

<sup>3</sup> The device variant with THIES ACII interpreter is supplied with CI0, the variant with MODBUS RTU with CI1.

<sup>4</sup> The device variant with THIES ACII interpreter is supplied with ID0, the variant with MODBUS RTU with ID1. If the sensor contains an additional label with the ID, the ID of the label is valid.

### 10.2.1 Command BR

<id>BR<parameter><CR> Set the baud rate

Access: Read / write

Description: The baud rate is set with the command BR

Parameter Type: Unsigned integer

Parameter:

Parameter	Description
12	1200baud
24	2400baud
48	4800baud
96	9600baud
192	19200baud
384	38400baud
576	57600baud

Type return value: unsigned integer

Return value: See parameter

Value range: 1200 / 2400 / 4800 / 9600 / 19200 / 38400 / 57600

Initial value: 9600

### 10.2.2 Command CF

<id>CF<parameter><CR> Calibration status

Access: Read

Description: The calibration status is queried with the CF command. In the case of calibrated measuring elements, the calibration status is set to one at the factory. When replacing the hygro-thermo measuring element later, the error "invalid replacement of hygro-thermo measuring element" is displayed. Even if the status was not set, the measuring element was adjusted in manufacturing.

Parameter Type: Unsigned integer

Parameter:

Parameter	Description
0	Without calibration
1	With calibration

Type Return value: Unsigned integer

Return value: See parameter

Range of values: 0 up to 1

Initial value: 0

### 10.2.3 Command CI

<id>CI<parameter><CR> Selection of the command interpreter

Access: Read / write

Description: The command interpreter is set with the command CI.

**Note:**

*If the identification number (ID) is greater than 98, it is automatically set to 0 with switching to the THIES interpreter!*

**Note:**

*If the identification number (ID) is 0, switching to the MODBUS-RTU interpreter is not then possible!*

Parameter Description:

Parameter	Description
0	THIES
1	MODBUS RTU

Range of values: 0 up to 1

Initial value: 0/1 depending on the device version.

0 with THIES ACII interpreter, 1 with MODBUS RTU

### 10.2.4 Command EDC

<id>EDC<parameter><CR> Maintenance of the particulate matter sensor (dust cleaning)

Access: Read / write

Parameter Description: Indicates whether manual maintenance of the particulate matter sensor is currently being performed. When called up with parameter 1, maintenance of the particulate matter sensor is started outside of the automated interval. Frequent maintenance calls in addition to automatic maintenance can shorten the service life of the particulate matter sensor.

Type Return value: unsigned integer

Return value: 0, if manual maintenance is not currently being performed

1, during manual maintenance

Range of values: 0, 1

Initial value: 0

## 10.2.5 Command EFS

<id>EFS<parameter><CR> Status of the sensor (Extended Fault Status)

Access: Read

Description: The command returns the status of the Hygro-Thermo-Baro transducer. For each module of the Hygro-Thermo-Baro-Transducer the telegram sends a line with the name of the module and followed by the status. If a module is error-free, an OK is returned. Otherwise, the error code is returned. The telegram output depends on the variant. In the case of digital variants, for example, analog output is not output.

Parameter Type: -

Parameter: -

Type Return value: Character string

Return value: Status in hexadecimal form or OK

Sample answer:

```

Fault status:
Main board:      OK
Air pres.:      OK
Dust:           OK

Meas. element:  OK
I2C:            OK
EEPROM:         OK
SHT Humidity:   OK
RH Humidity:    OK
SHT35 Temp.:    OK
PT1000 Temp.:   OK
Dew point:      OK

```

### Error code description:

Mainboard error:

Bit 0: Vcc error, voltage in invalid range  
 Bit 1: 3v  $\mu$ C internal voltage error

Air pressure sensor error (only if air pressure measurement is active):

Bit 0: Chip ID error  
 Bit 1: Calculation error during initialization  
 Bit 2: Calculation error in measurement mode  
 Bit 3: Status bytes read wrong  
 Bit 4: Wrong number of bytes read  
 Bit 5: Air pressure invalid value range.  
 Bit 6: Temperature invalid range of values.  
 Bit 7: Sensor switched off

Particulate matter error:

- Bit 0: Sensor not found
- Bit 1: Readings delayed
- Bit 2: Fan speed out of normal range
- Bit 3: Fan error
- Bit 4: Laser error

Measuring element error (Hygro thermo modul):

- Bit 0: Module initialization error
- Bit 1: I2C error
- Bit 2: EEPROM read error
- Bit 3: EEPROM Page1 invalid
- Bit 4: Module mode error
- Bit 5: Sensor error
- Bit 6: unknown measuring element

I2C bus error:

- Bit 0: I2C activation error
- Bit 1: I2C write error
- Bit 2: I2C read error

EEPROM error:

- Bit 0: Module initializes but no valid measured value available
- Bit 1: CRC error
- Bit 2: Read error
- Bit 3: Write error
- Bit 4: Reading mirrored area failed
- Bit 5: Error writing to mirrored area
- Bit 6: Wrong address
- Bit 7: Value range error
- Bit 8: Free
- Bit 9: Item number wrong
- Bit 10: Sensor ID error
- Bit 11: Write request error
- Bit 12: no measuring element
- Bit 13: Pages have been fixed

Temperature and humidity errors:

- Bit 0: Measured value initialized but not yet a valid measured value
- Bit 1: Timed out writing
- Bit 2: Timed out reading
- Bit 3: CRC error
- Bit 4: calculation error
- Bit 5: Diagnostic mode, measurement invalid
- Bit 6: Calibration value invalid
- Bit 7: Invalid self-calibration parameter (humidity only)
- Bit 8: Initialization error 2
- Bit 9: Calculation error 2

Moisture correction error:

- Bit 0: Module initialised, no valid measured value available yet.
- Bit 1: Incorrect humidity input value
- Bit 2: Input value sensor temperature faulty
- Bit 3: Incorrect air temperature input value
- Bit 4: calculated temperature too small
- Bit 5: Table index too large
- Bit 6: calculated humidity < 0%
- Bit 7: calculated humidity > 100%

PT1000 Modul Fehler:

- Bit 0: Module initialised, no valid measured value available yet.
- Bit 1: Initialization "shut down" error
- Bit 2: Wake up failed
- Bit 3: Start measurement failed
- Bit 4: Get reading failed
- Bit 5: Shut down failed
- Bit 6: Calculation failed
- Bit 7: free
- Bit 8: wrong mode
- Bit 9: Failed to read parameters
- Bit 10: Gain parameter invalid
- Bit 11: Invalid parameter offset

Dew point calculation error:

- Bit 0: Module initialised, no valid measured value available yet.
- Bit 1: Input value humidity invalid
- Bit 2: Input value temperature invalid
- 0xFFFF -> Query error, parameters of called function not valid.

### 10.2.6 Command FB

<id>FB<parameter><CR>	Quick start mode
Access:	Read / write
Description:	<p>The command is used to select the quick start mode or to query the set mode.</p> <p>In the quick start modes, the bootloader immediately jumps into the firmware and does not output any data. If the quick start mode is inactive, the bootloader outputs its software version, 9 times the C and the set parameters BR, SF, CI and ID.</p> <p>In quick start mode 1, the firmware does not output a telegram for the encoder status. In quick start modes 0 and 2, the firmware outputs the "LL" telegram once after the start.</p>
Parameter Type:	Unsigned integer
Parameter:	<p>0: Quick start mode off</p> <p>1: Quick start mode on (without telegram output)</p> <p>2: Quick start mode on (only telegram LL is sent once)</p>
Type Return value:	Unsigned integer
Return value:	See parameter
Range of values:	0...2
Initial value:	1

### 10.2.7 Command HW

<id>ID<parameter><CR>	Hardware configuration
Access:	Read
Description:	<p>The command is used to read out the type of hardware. At the start, the hardware variant and the configuration are read out and checked for plausibility. The result of this plausibility check is read out with this command.</p>
Parameter Type:	Unsigned integer
Parameter:	<p>0: Digital</p> <p>1: HTB with power output</p> <p>2: HTB with voltage output</p> <p>3: Reserved</p> <p>4: Hardware invalid</p>
Type Return value:	Unsigned integer
Return value:	See parameter
Range of values:	0 ... 4
Initial value:	-



### 10.2.8 Command ID

**<id>ID<parameter><CR>** Identification number

**Access:** Read / write

**Description:** This command sets the identification number (THIES interpreter) or the slave address (MODBUS RTU interpreter). A response telegram is sent only when the 'ID' in the command matches the one set in the sensor. An exception here is the generic 'ID', to which all sensors respond (THIES interpreter). Once the 'ID' has been changed, the device will immediately respond with the new 'ID'.

**Parameter Type:** Unsigned integer

**Parameter:**  
 99 generic 'ID' (THIES interpreter)  
 0 Broadcast slave address (MODBUS RTU interpreter)

**Type Return value:** Unsigned integer

**Return value:** See parameter

**Range of values:**  
 0 up to 99 (THIES Interpreter)  
 1 up to 247 (MODBUS RTU Interpreter)

**Initial value:**  
 0 (THIES Interpreter) für Sensor 1.1006.54.xxx  
 1 (MODBUS RTU Interpreter) für Sensor 1.1006.54.xx1

### 10.2.9 Command KY

**<id>KY<parameter><CR>** Key/password

**Access:** Read / write

**Description:** The value for the key (password) is set with this command. The following 2 password levels are possible:

- Query (only read access)
- User (general settings)
- Admin (Thies version configuration)
- Calibration (calibration laboratories)

**Parameter Type:** Unsigned integer

**Parameter:**

Parameter	Description
Without	Query = read
1	User
-	Admin (Thies internal)
On request	Calibration for laboratories

**Type Return value:** Unsigned integer

**Return value:** See parameter

**Range of values:** 0, 1, ...

**Initial value:** 0

### 10.2.10 Command LL

<id>LL<CR> System status query  
 Access: Read  
 Description: System information for the sensor is output with this command.  
 Type Return value: Text  
 Return value:

```

Product description:
PM-Hygro-Thermo-Baro- Sensor COMPACT
Article number      : 1.1007.54.780
PCB number          : 510462
Hardware version    : VER-04-22
Hardware            : digital output
Serial number       : 00000000
FW version          : V03.13
Sensor ID           : 00
Thies Interpreter is active
Automatic send of data is disabled.
Fast boot is enabled.

Satellite data:
Article number      : 510481
Hardware version    : VER-09-21
Serial number       : 00AAA001
END
  
```

### 10.2.11 Command OR

<id>OR< parameter > Telegram output interval (Output Rate)  
 Access: User mode  
 Description: With independent telegram output this parameter is used to specify the time interval in which telegrams are output via the serial interface. Specification is in milliseconds. If the output speed is higher than the data can be transmitted, the available output is discarded.  
 If the output is faster than acquisition of the measured values, the measured values available are output again.  
 The parameter OR does not influence data acquisition; the internal sampling rate of the data is fixed to 1 second.  
 See also **Command TT**.  
 ParameterDescription:  
 0: → A telegram is always output when internal measured value acquisition has calculated a new data set.  
 1...60000 → Specifies the output interval in milliseconds.  
 Range of values: 0...60000 [ms]  
 Initial value: 1000

### 10.2.12 Command PO

<id>PO<parameter><CR> Air pressure offset

Access: Read

Description: The pressure offset is reset with this command. The pressure offset is selected with adjustment of the sensor on initial start-up.  
The parameter / return value has an offset of 5000 related to the offset of the sensor. An increase or decrease in the parameter of +/-1 results in an offset correction of +/-0.01hPa.

Type Return value: Query (only read access)  
Integer

Description: 4900 -> -1 hPa  
5000 -> 0 hPa  
5100 -> +1 hPa

The following applies: output value = measured value + offset

Range of values: 4000 ... 6000

Initial value: 5000

### 10.2.13 Command RD

<id>RD<parameter> Delayed response (Response Delay)

Access: Read / write

Description: With this command the response is delayed by the time specified in ms following a command via the serial interface

Range of values: 0 ... 1000

Initial value: 20

Unit: ms

### 10.2.14 Command RS

<id>RS<parameter><CR> Reset

Access: Read / write

Description: The command RS is used to query the reset source (read without parameter) or to perform reset/restart (write with parameter). Write with a parameter returns a standard response with a parameter value without a leading sign. Read gets back a text stream with the reset source.

The following reset sources can be output:

BOR	(Power On Reset Flag)
EXT	(External Reset Flag)
BODCORE	(Brownout Detection Core)
BODVDD	(Brownout Detection Power Supply)
WDT	(Watchdog Reset Flag)
SYST	(System Reset)
invalid	(all other cases)

Parameter Type: Unsigned integer

Parameter: 1 Watchdog Reset  
2 Software Reset

Type Return value: Integer without a leading sign or text stream (see Description)

Return value: Parameter or text stream

Range of values: 1 / 2

Initial value: -

### 10.2.15 Command SF

<id>SF<parameter><CR>	Frame format
Access:	Read / write
Description:	The frame format of the interface is set with the command SF
Parameter Type:	Unsigned integer
Parameter:	0: 8N1 (8 data bits, no parity, 1 stop bit) 1: 8N2 (8 data bits, no parity, 2 stop bits) 2: 8E1 (8 data bits, even parity, 1 stop bit) 3: 8E2 (8 data bits, even parity, 2 stop bits) 4: 8O1 (8 data bits, odd parity, 1 stop bit) 5: 8O2 (8 data bits, odd parity, 2 stop bits) 6: 7E1 (7 data bits, even parity, 1 stop bit) 7: 7N1 (7 data bits, no parity, 1 stop bit)
Type Return value:	Unsigned integer
Return value:	See parameter
Range of values:	0 ... 7
Initial value:	0

### 10.2.16 Command SH

<id>SH<parameter><CR>	Station height
Access:	Read / write
Description:	<p>The station height at the sensor site is set with this command. This value is used to calculate the reduced air pressure. The height is specified in metres.</p> <p>It is necessary to specify the station height to calculate the reduced air pressure at sea level. If the station height is 0m, the value output for the reduced air pressure and the absolute air pressure are identical.</p>
Parameter Type:	Unsigned integer
Parameter:	Height above sea level in metres -500 ... 10000: station height in metres. Basis for calculating the reduced air pressure
Type Return value:	Unsigned integer
Return value:	See parameter
Range of values:	-500 ... 10000
Initial value:	0

### 10.2.17 Command SN

<id>SN<parameter><CR> Serial number  
Access: Read  
Description: The command enables the serial number to be read.  
Parameter Type: -  
Parameter: -  
Type Return value: Unsigned integer  
Return value: xxxxxxxxxx: serial number  
Range of values: xxxxxxxxxx  
Initial value: -

### 10.2.18 Command TA

<id>TA<parameter><CR> Thies part number  
Access: Read  
Description: Returns the article number with the hardware version. The article number is queried with Parameter 1 and Parameter 2, e.g. 00TA1 and 00TA2.  
  
Query (only read access)  
Type Return value: Unsigned integer  
Return value: 00TA11006  
00TA54080  
Together, this results in the article number  
1.1006.54.080

### 10.2.19 Command TR

<id>TR<parameter><CR>	Measured value request
Access:	Read
Description:	The command initiates one-off transmission of the current data telegram.
Parameter Type:	Unsigned integer
Parameter:	1: Query measured value telegram 1 ... 6 Query measured value telegram 6
Type Return value:	Character string
Return value:	Character string (see <b>Telegram formats</b> and <b>Telegrams</b> )
Range of values:	1 ... 6
Initial value:	-

### 10.2.20 Command TT

<id>TT<parameter>	Independent telegram output (Telegram Transmission)
Access:	User mode
Description:	Specifies the number of the telegram that the ULTRASONIC transmits independently on a cyclic basis. The same telegrams are available as described under <b>Command TR</b> . To switch off independent telegram output, the parameter of TT must be set to 0.
Type Return value:	Character string
Return value:	See <b>Telegrams</b>
Range of values:	0 ... 6
Initial value:	0

**Note:**

*The sensor is equipped with a half duplex interface. If the sensor is set to automatic telegram output, commands can only be sent to the sensor without errors within the first 60 seconds. When commands are sent during independent telegram output, communication errors can occur.*

## 10.3 Command Interpreter MODBUS RTU

If the MODBUS RTU command interpreter is selected, the transferred bytes are interpreted according to the MODBUS specification (<http://www.modbus.org/>). The sensor represents a MODBUS slave here.

Data transfer takes place in packets known as frames, max. 256 bytes in size. Each packet contains a 16bit CRC checksum (Initial value: 0xffff).

Slave address	Functional code	Data	CRC	
1byte	1byte	0 ... 252 byte(s)	2Bytes	
			CRC low-byte	CRC high-byte

**Table 5: MODBUS Frame**

The following MODBUS functions are supported:

- 0x04 (Read Input Register).
- 0x03 (Read Holding Registers).
- 0x10 (Write Multiple Registers).
- 0x2B (Read Device Identification with MEI-Type 0x0E).

The wind sensor supports writing accesses for the slave address 0 ("broadcast").

All MODBUS requests received are checked for validity prior to execution. In the event of an error the sensor responds with one of the following exceptions (→MODBUS Exception Responses):

Code	Name	Meaning
0x01	ILLEGAL FUNCTION	The functional code in the request is not admissible for the register address.
0x02	ILLEGAL DATA ADDRESS	The register address in the request is not valid.
0x03	ILLEGAL DATA VALUE	The specified data in the request is not admissible.

**Table 6: MODBUS Exceptions**



### 10.3.1 Measured Values (Input Register)

All measured values of the sensor occupy 32bit, i.e. 2 MODBUS register addresses. The following table shows assignment of the measured value to an register address, with the measured values being sorted as given below:

- According to measured value Type (30001 to 34999).
- In uninterrupted sequence (35001 to 39999).

Register address	Parameter name	Unit	Multiplier	Explanation	Data Type
30401	Air temperature (35007) <sup>1</sup>	°C	10	Value / 10 (1 Decimal place, e.g. 255=25.5°C)	S32
30601	Rel. humidity (35005) <sup>1</sup>	%r.F.	10	Value / 10 (1 Decimal place, e.g. 355=35.5%r.F.)	U32
30603	Absolute humidity (35007) <sup>1</sup>	g/m <sup>3</sup>	100	Value / 100 (2 Decimal place, e.g. 923 $\triangleq$ 9.23 g/m <sup>3</sup> )	U32
30605	Dew point temperature (35009) <sup>1</sup>	°C	10	Value / 10 (1 Decimal place, e.g. 115=11.5°C)	S32
30601	Rel. humidity (35005) <sup>1</sup>	%r.F.	10	Value / 10 (1 Decimal place, e.g. 355 $\triangleq$ 35.5 %r.F.)	U32
30603	Abs. humidity (35007) <sup>1</sup>	g/m <sup>3</sup>	100	Value / 100 (2 Decimal place, e.g. 923 $\triangleq$ 9.23 g/m <sup>3</sup> )	U32
30605	Dew point temperature (35011) <sup>1</sup>	°C	10	Value / 10 (1 Decimal place, e.g. 115 $\triangleq$ 11.5 °C)	S32
30801	Absolute air pressure (QFE) (Unit: hPa) (35001) <sup>1</sup>	hPa	10	Value / 10 (1 Decimal place, e.g. 10500=1050.0hPa)	U32
30803	Reduced air pressure (QNH) (Unit: hPa) (35003) <sup>1</sup>	hPa	10	Value / 10 (1 Decimal place, e.g. 10500=1050.0hPa)	U32

31601	Particulate matter mass density < 1 $\mu$ m PM1 (35013) <sup>1</sup>	$\mu$ g/m <sup>3</sup>	10	Value / 10 (1 Decimal place, e.g. 20 $\triangleq$ 2.0 $\mu$ g/m <sup>3</sup> )	U32
31603	Particulate matter mass density < 2,5 $\mu$ m PM2.5 (35015) <sup>1</sup>	$\mu$ g/m <sup>3</sup>	10	Value / 10 (1 Decimal place, e.g. 20 $\triangleq$ 2,0 $\mu$ g/m <sup>3</sup> )	U32

31605	Particulate matter mass density < 4 µm PM4 (35017) <sup>1</sup>	µg/m <sup>3</sup>	10	Value / 10 (1 Decimal place, e.g. 55 ± 5,5 µg/m <sup>3</sup> )	U32
31607	Particulate matter mass density < 10 µm PM10 (35019) <sup>1</sup>	µg/m <sup>3</sup>	10	Value / 10 (1 Decimal place, e.g. 134 ± 13,4 µg/m <sup>3</sup> )	U32
31609	Particulate matter density up to 0,5 µm (35021) <sup>1</sup>	1/cm <sup>3</sup>	10	Value / 10 (1 Decimal place, e.g. 148 ± 14.8 1/cm <sup>3</sup> )	U32
31611	Particulate matter density up to 1 µm (35023) <sup>1</sup>	1/cm <sup>3</sup>	10	Value / 10 (1 Decimal place, e.g. 200 ± 20.0 1/cm <sup>3</sup> )	U32
31613	Particulate matter density up to 2,5 µm (35025) <sup>1</sup>	1/cm <sup>3</sup>	10	Value / 10 (1 Decimal place, e.g. 234 ± 23.4 1/cm <sup>3</sup> )	U32
31615	Particulate matter density up to 4 µm (35027) <sup>1</sup>	1/cm <sup>3</sup>	10	Value / 10 (1 Decimal place, e.g. 567 ± 56.7 1/cm <sup>3</sup> )	U32
31617	Particulate matter density up to 10 µm (35029) <sup>1</sup>	1/cm <sup>3</sup>	10	Value / 10 (1 Decimal place, e.g. 700 ± 70.0 1/cm <sup>3</sup> )	U32
31619	Mean dust particle size (35031) <sup>1</sup>	µm	10	Value / 10 (1 Decimal place, e.g. 16 ± 1.6 µm)	U32
31621	Particulate matter measurement quality indicator (35033)		1	Value (no decimal place, 0±undefined/error, 1±low, 4±ideal)	U32
Complete sequence of the measured values at start of 35001					
35001	Absolute air pressure (QFE) (Unit: hPa) (30801)	hPa	10	Value / 10 (1 Decimal place, e.g. 10500=1050.0hPa)	U32
35003	Reduced air pressure (QNH) (Unit: hPa) (30803)	hPa	10	Value / 10 (1 Decimal place, e.g. 10500=1050.0hPa)	U32
35005	Rel. humidity (30601)	%r.F.	10	Value / 10 (1 Decimal place, e.g. 355=35.5%r.F.)	U32
35007	Air temperature (30401)	°C	10	Value / 10 (1 Decimal place, e.g. 255=25.5°C)	S32
35009	Dew pointtemperatur (30609)	°C	10	Value / 10 (1 Decimal place, e.g. 115=11.5°C)	S32
35011	Sensorstatus			Sensor status, see chapter 10.1.3	
35013	Particulate matter mass density < 1 µm PM1 (31601)	µg/m <sup>3</sup>	10	Value / 10 (1 Decimal place, e.g. 20 ± 2.0 µg/m <sup>3</sup> )	U32
35015	Particulate matter mass density < 2,5 µm PM2.5 (31603)	µg/m <sup>3</sup>	10	Value / 10 (1 Decimal place, e.g. 115 ± 11.5 µg/m <sup>3</sup> )	U32

35017	Particulate matter mass density < 4 µm PM4 (31605)	µg/m <sup>3</sup>	10	Value / 10 (1 Decimal place, e.g. 355 ± 35.5 µg/m <sup>3</sup> )	U32
35019	Particulate matter mass density < 10 µm PM10 (31607)	µg/m <sup>3</sup>	10	Value / 10 (1 Decimal place, e.g. 550 ± 55.0 µg/m <sup>3</sup> )	U32
35021	Particulate matter density up to 0,5 µm (31609)	1/cm <sup>3</sup>	10	Value / 10 (1 Decimal place, e.g. 355 ± 35.5 1/cm <sup>3</sup> )	U32
35023	Particulate matter density up to 1 µm (31611)	1/cm <sup>3</sup>	10	Value / 10 (1 Decimal place, e.g. 402 ± 40.2 1/cm <sup>3</sup> )	U32
35025	Particulate matter density up to 2,5 µm (31613)	1/cm <sup>3</sup>	10	Value / 10 (1 Decimal place, e.g. 567 ± 56.7 1/cm <sup>3</sup> )	U32
35027	Particulate matter density up to 4 µm (31615)	1/cm <sup>3</sup>	10	Value / 10 (1 Decimal place, e.g. 600 ± 60.0 1/cm <sup>3</sup> )	U32
35029	Particulate matter density up to 10 µm (31617)	1/cm <sup>3</sup>	10	Value / 10 (1 Decimal place, e.g. 673 ± 67.3 1/cm <sup>3</sup> )	U32
35031	Mean dust particle size (31619)	µm	10	Value / 10 (1 Decimal place, e.g. 23 ± 2.3 µm)	U32
35033	Particulate matter measurement quality indicator (31621)		1	Value (no decimal place, 0±undefined/error, 1±low, 4±ideal)	U32
35035	Sensorstatus			Sensorstatus, see 10.1.3	U32

**Table 7: MODBUS Input Register**

<sup>1)</sup> The numbers in brackets indicate the register addresses which represent the same measured values. So is the Air temperature for example is at both address 30401 and address 35007.

**Note:**

**Continuous ordering of the measured values from address 35001 allows the MODBUS master to read out all measured values with a single request.**

### 10.3.2 Commands (Holding Register)

All commands of the sensor occupy 32bit, i.e. 2 MODBUS register addresses and represent integers without a leading sign.

The commands available for parameter setting are listed in Section **10.2 Commands and Description**. The MODBUS register addresses for the commands are listed in **Table 3**.

The following example shows a change in the baud rate to 19200 baud.

### 1. Set password for the user level (KY=1)

Slave address	Functional code	Start address	Number register	Number byte(s)	Data	CRC	
0x01	0x10	0x9C 49	0x00 02	0x04	0x00 00 00 01	0x0F 33	
						CRC low-byte	CRC high-byte

### 2. Set command baud rate to 19200 baud (BR=192)

Slave address	Functional code	Start address	Number register	Number byte(s)	Data	CRC	
0x01	0x10	0x9C 45	0x00 02	0x04	0x00 00 00 C0	0xCE F6	
						CRC low-byte	CRC high-byte

The commands available for parameter setting are listed in the chapter 10.2 commands and description.

## 11 Data Telegrams

### 11.1 Telegram 1

The sensor responds to the command "00TR1r" with the measured value telegram. The telegram outputs the most important measured values including the particulate matter measured values PM2.5 and PM10. The telegram structure is shown in the following table:

Position	Length	Sample	Description
1	1	STX	Start sign (start of text).
2	2	xx	Identification number (ID) xx: 0 ... 98
4	1	;	Separation sign (';')
5	6	1002.3	Reduced air pressure at sea level, (QNH) (see command SH)
11	1	;	Separation sign (';')
12	5	045.3	Rel. humidity
17	1	;	Separation sign (';')
18	5	+24.3	Air temperature in degrees Celsius
23	1	;	Separation sign (';')
24	6	0012.1	Particulate matter mass density up to 2.5µm (PM2.5) in µg/m <sup>3</sup>
30	1	;	Separation sign (';')
31	6	0035.7	Particulate matter mass density up to 10µm (PM10) in µg/m <sup>3</sup>
37	1	;	Separation sign (';')
38	1	4	Particulate matter measurement quality indicator (see chapter 4 Measurements at high humidity and fog)
39	1	;	Separation sign (';')
40	4	0000	Sensor status (see status information)
44	1	*	Checksum identifier (*)
45	2	xy	Exclusive or linked checksum in hexadecimal format x: high nibble checksum in HEX

Position	Length	Sample	Description
			y: low nibble checksum in HEX
47	1	CR	Carriage return
48	1	LF	Line feed
49	1	ETX	End of text

**Table 8: Measured value telegram 1**

## 11.2 Telegram 2

The sensor responds to the command "00TR2\r" with the measured value telegram. with the hygro-thermo-baro-particulate-telegram. In addition to telegram 1, the telegram outputs the dew point, the absolute humidity and the reduced air pressure. The telegram structure is shown in the following table:

Position	Length	Sample	Description
1	1	STX	Start sign (start of text).
2	2	xx	Identification number (ID) xx: 0 ... 98
4	1	;	Separation sign (';')
5	6	1002.3	Absolute air pressure (QFE) in hPa
11	1	;	Separation sign (';')
12	6	1012.3	Reduced air pressure at sea level, (QNH) (see command SH)
18	1	;	Separation sign (';')
19	5	045.3	Rel. humidity in %
24	1	;	Separation sign (';')
25	5	+24.3	Air temperature in degrees Celsius
30	1	;	Separation sign (';')
31	5	+03.4	Dew point degrees celsius
36	1	;	Separation sign (';')
37	5	011.5	Abs. humidity in g/m <sup>3</sup>
42	1	;	Separation sign (';')
43	6	0005.7	Particulate matter mass density up to 2.5 µm (PM2.5) in µg/m <sup>3</sup>
49	1	;	Separation sign (';')
50	6	0017.5	Particulate matter mass density up to 10 µm (PM10) in µg/m <sup>3</sup>
56	1	;	Separation sign (';')
57	1	4	Particulate matter measurement quality indicator (see Chapter 4 Measurements at high humidity and fog)
58	1	;	Separation sign (';')
59	4	0000	Sensor status (see status information)
63	1	*	Checksum identifier (*)
64	2	xy	Exclusive or linked checksum in hexadecimal representation x: high nibble checksum in HEX y: low nibble checksum in HEX
66	1	CR	Carriage return
67	1	LF	Line feed
68	1	ETX	End of text

**Table 9: Measured value telegram 2**

## 11.3 Telegram 3

The sensor responds to the command "00TR3\r" with the complete measured value telegram. The telegram structure is shown in the following table:

Position	Length	Sample	Description
1	1	STX	Start sign (start of text).
2	2	xx	Identification number (ID) xx: 0 ... 98
4	1	;	Separation sign (';')
5	6	1002.3	Absolute air pressure (QFE) in hPa
11	1	;	Separation sign (';')
12	6	1002.3	Reduced air pressure at sea level, (QNH) (see command SH)
18	1	;	Separation sign (';')
19	5	045.3	Rel. humidity in %
24	1	;	Separation sign (';')
25	6	+24.3	Air temperature in degrees Celsius
31	1	;	Separation sign (';')
32	6	+03.4	Dew point degrees celsius
38	1	;	Separation sign (';')
39	5	011.5	Abs. humidity in g/m <sup>3</sup>
44	1	;	Separation sign (';')
45	6	0004.5	Particulate matter mass density up to 1 µm (PM1) in µg/m <sup>3</sup>
51	1	;	Separation sign (';')
52	6	0011.2	Particulate matter mass density up to 2.5 µm (PM2.5) in µg/m <sup>3</sup>
58	1	;	Separation sign (';')
59	6	0004.1	Particulate matter mass density up to 4 µm (PM4) in µg/m <sup>3</sup>
65	1	;	Separation sign (';')
66	6	0005.7	Particulate matter mass density up to 10 µm (PM10) in µg/m <sup>3</sup>
72	1	;	Separation sign (';')
73	6	0040.9	Particulate matter density up to 0,5 µm in 1/cm <sup>3</sup>
79	1	;	Separation sign (';')
80	6	0046.6	Particulate matter density up to 1 µm in 1/cm <sup>3</sup>
86	1	;	Separation sign (';')
87	6	0050.8	Particulate matter density up to 2,5 µm in 1/cm <sup>3</sup>
93	1	;	Separation sign (';')
94	6	0056.1	Particulate matter density up to 4 µm in 1/cm <sup>3</sup>
100	1	;	Separation sign (';')
101	6	0077.9	Particulate matter density up to 10 µm in 1/cm <sup>3</sup>
107	1	;	Separation sign (';')
108	4	00.5	Average dust particle size in µm
112	1	;	Separation sign (';')
113	1	4	Particulate matter measurement quality indicator (see Chapter 4 Measurements at high humidity and fog)
114	1	;	Separation sign (';')
115	4	0000	Sensor status (see status information)
119	1	*	Checksum identifier (*)
120	2	xy	Exclusive or linked checksum in hexadecimal representation x: high nibble checksum in HEX y: low nibble checksum in HEX
122	1	CR	Carriage return

Position	Length	Sample	Description
123	1	LF	Line feed
124	1	ETX	End of text

**Table 10: Measured value telegram 3**

## 11.4 Telegram 4

The sensor responds to the command "00TR4r" with the complete measured value telegram. The internal supply voltage is also output. The telegram structure is shown in the following table:

Position	Length	Sample	Description
1	1	STX	Start sign (start of text).
2	2	xx	Identification number (ID) xx: 0 ... 98
4	1	;	Separation sign (';')
5	6	1002.3	Absolute air pressure (QFE) in hPa
11	1	;	Separation sign (';')
12	6	1002.3	Reduced air pressure at sea level, (QNH) (see command SH)
18	1	;	Separation sign (';')
19	5	045.3	Rel. humidity in %
24	1	;	Separation sign (';')
25	5	+24.3	Air temperature in degrees Celsius
30	1	;	Separation sign (';')
31	5	+03.4	Dew point degrees celsius
36	1	;	Separation sign (';')
37	5	011.5	Abs. humidity in g/m <sup>3</sup>
42	1	;	Separation sign (';')
43	6	0004.5	Particulate matter mass density up to 1 µm (PM1) in µg/m <sup>3</sup>
49	1	;	Separation sign (';')
50	6	0011.2	Particulate matter mass density up to 2.5 µm (PM2.5) in µg/m <sup>3</sup>
56	1	;	Separation sign (';')
57	6	0004.1	Particulate matter mass density up to 4 µm (PM4) in µg/m <sup>3</sup>
63	1	;	Separation sign (';')
64	6	0005.7	Particulate matter mass density up to 10 µm (PM10) in µg/m <sup>3</sup>
70	1	;	Separation sign (';')
71	6	0040.9	Particulate matter density up to 0,5 µm in 1/cm <sup>3</sup>
77	1	;	Separation sign (';')
78	6	0046.6	Particulate matter density up to 1 µm in 1/cm <sup>3</sup>
84	1	;	Separation sign (';')
85	6	0050.8	Particulate matter density up to 2,5 µm in 1/cm <sup>3</sup>
91	1	;	Separation sign (';')
92	6	0056.1	Particulate matter density up to 4 µm in 1/cm <sup>3</sup>
98	1	;	Separation sign (';')
99	6	0077.9	Particulate matter density up to 10 µm in 1/cm <sup>3</sup>
105	1	;	Separation sign (';')
106	4	00.5	Average dust particle size in µm
110	1	;	Separation sign (';')
111	6	11.402	Internal supply voltage in volts

Position	Length	Sample	Description
117	1	;	Separation sign (';')
118	1	4	Particulate matter measurement quality indicator (see Chapter 4 Measurements in high humidity and fog)
119	1	;	Separation sign (';')
120	4	0000	Sensor status (see status information)
124	1	*	Checksum identifier (*)
125	2	xy	Exclusive or linked checksum in hexadecimal representation x: high nibble checksum in HEX y: low nibble checksum in HEX
127	1	CR	Carriage return
128	1	LF	Line feed
129	1	ETX	End of text

**Table 11: Measured value telegram 4**

## 11.5 Telegram 5

The sensor responds to the command "00TR5 \ r" with the Measured value telegram. The telegram outputs the measured information from telegram 2 as well as internal voltages and sensor status in plain text.

Example:

```

Sensor ID:                00
Air pressure:             0986.6hPa
QNH:                     1012.6hPa
relative Humidity:       047.4%rel.H.
absolute Humidity:       011.2g/m^3
Temperature:             +25.4deg.C
Dew point:               +13.4deg.C
PM2.5:                   0006.0ug/m^3
PM10:                    0006.0ug/m^3
PM significance:        4/4
Voltage Vcc:             22.278V
Voltage 3.3V:           3.407V
Hardware version:       VER-07-22
Sensor Status:          0000

```



## 11.6 Telegram 6

The sensor responds to the "00TR6\r" command with the complete measured value telegram. This telegram specifies the temperature and pressure values with one more decimal place and should be used to calibrate the hygro, thermo and baro sensors. The telegram structure is shown in the following table:

Position	Length	Sample	Description
1	1	STX	Start sign (start of text).
2	2	xx	Identification number (ID) xx: 0 ... 98
4	1	;	Separation sign (';')
5	7	1002.32	Absolute air pressure (QFE) in hPa
12	1	;	Separation sign (';')
13	7	1002.32	Reduced air pressure at sea level, (QNH) (see command SH)
20	1	;	Separation sign (';')
21	5	045.3	Rel. humidity in %
26	1	;	Separation sign (';')
27	6	+24.37	Air temperature in degrees Celsius
33	1	;	Separation sign (';')
34	6	+03.48	Dew point degrees celsius
40	1	;	Separation sign (';')
41	5	011.5	Abs. humidity in g/m <sup>3</sup>
46	1	;	Separation sign (';')
47	6	0004.5	Particulate matter mass density up to 11 µm (PM1) <sup>9</sup> in µg/m <sup>3</sup>
53	1	;	Separation sign (';')
54	6	0011.2	Particulate matter mass density up to 12.5 µm (PM2.5) in µg/m <sup>3</sup>
60	1	;	Separation sign (';')
61	6	0004.1	Particulate matter mass density up to 14 µm (PM4) <sup>9</sup> in µg/m <sup>3</sup>
67	1	;	Separation sign (';')
68	6	0005.7	Particulate matter mass density up to 110 µm (PM10) in µg/m <sup>3</sup>
74	1	;	Separation sign (';')
75	6	0040.9	Particulate matter mass density <sup>9</sup> bis 0,5 µm in 1/cm <sup>3</sup>
81	1	;	Separation sign (';')
82	6	0046.6	Particulate matter mass density <sup>9</sup> bis 1 µm in 1/cm <sup>3</sup>
88	1	;	Separation sign (';')
89	6	0050.8	Particulate matter mass density <sup>9</sup> bis 2,5 µm in 1/cm <sup>3</sup>
95	1	;	Separation sign (';')
96	6	0056.1	Particulate matter mass density <sup>9</sup> bis 4 µm in 1/cm <sup>3</sup>
102	1	;	Separation sign (';')
103	6	0077.9	Particulate matter mass density <sup>9</sup> bis 10 µm in 1/cm <sup>3</sup>
109	1	;	Separation sign (';')
110	4	00.5	Average dust particle size <sup>9</sup> in µm
114	1	;	Separation sign (';')
115	6	11.402	Internal supply voltage in volts
121	1	;	Separation sign (';')
122	1	4	Particulate matter measurement quality indicator (see Chapter 4 Measurements in high humidity and fog)
123	1	;	Separation sign (';')
124	4	0000	Sensor status (see status information)
128	1	*	Checksum identifier (*)

Position	Length	Sample	Description
129	2	xy	Exklusiv oder verknüpfte Prüfsumme in hexadezimaler Darstellung x: high nibble Prüfsumme in HEX y: low nibble Prüfsumme in HEX
131	1	CR	Carriage return
132	1	LF	Line feed
133	1	ETX	End of text

**Table 12: Measured value telegram 6**

## 12 Technical Data

<b>Relative Humidity</b>	
Measuring range	0 ... 100% rel. Humidity
Accuracy	Typ. $\pm 1,5\%$ r. H. @ 25 °C and < 80% r. H. 1,5% r. H. over the complete measuring range
Long-term stability	Typ. < 0,25 rel. humidity / year
Setting time <sup>1</sup>	$\leq 35\text{sec}$
<b>Absolute Humidity</b>	
Accuracy <sup>2</sup>	Better than $\pm 0,15\text{g/m}^3$ @ -40 ... -20 °C Better than 6 % of measuring @ -20 ... +60 °C
<b>Air temperature</b>	
Measuring range	-40 ... +60 °C
Accuracy	$\pm 0,1^\circ\text{C}$ @ -40 ... +60 °C @ moved air > 2 m/s
Long-term stability	Max. $\leq 0,03^\circ\text{C} / \text{Year}$
Setting time <sup>1</sup>	$\leq 41\text{sec}$
<b>Dew point temperature</b>	
Accuracy <sup>2</sup>	Better than $\pm 2,0^\circ\text{C}$ @ 10 ... 100 % rel. humidity, -40 ... +60 °C
<b>Barometric pressure</b>	
Measuring range	300 ... 1200hPa
Accuracy	$\pm 0,25\text{hPa}$ @ -20 ... +60°C @ 800 ... 1100hPa $\pm 0,50\text{hPa}$ @ -20 ... +60°C @ 600 ... 800hPa
Long-term stability	$\pm 0,3\text{hPa} / \text{Year}$
Setting time <sup>1</sup>	$\leq 5\text{s}$
<b>Particulate matter</b>	
Measuring range	0 ... 1000 $\mu\text{g/m}^3$
Accuracy (without fog)	<b>PM2.5</b> @ -10...+60 °C $\pm 10 \mu\text{g/m}^3$ @ 0 ... 100 $\mu\text{g/m}^3$ $\pm 10\%$ of measuring @ 100 ... 1000 $\mu\text{g/m}^3$ <b>PM10</b> @ -10...+60 °C $\pm 25\mu\text{g/m}^3$ @ 0 ... 100 $\mu\text{g/m}^3$ $\pm 25\%$ of measuring @ 100 ... 1000 $\mu\text{g/m}^3$
Long-term stability	Better than $\pm 1,25\mu\text{g/m}^3 / \text{Year}$
<b>Electrical output</b>	
See 1. Models	RS 485 HD
<b>Serial interface</b>	Type RS485 Operating mode Half duplex mode Data format 8N1, 8N2, 8E1, 8E2, 8O1, 8O2, 7E1, 7N1 Baud rate 2400, 4800, 9600, 19200, 38400, 57600
Resolution (Telegram and interpreter dependent)	Air pressure: 0,01hPa (max.) Humidity: 0,1% rel. humidity Temperature: 0,01°C (max.) Particulate matter: 0,1 $\mu\text{g/m}^3$
Measurement rate	1s
Accuracy	See above

Supply voltage	Voltage: 12 ... 30V DC Measuring electronics via plug socket Ventilation via permanently connected cable
Power consumption	Measurement electronics: typ. 360mW max. 500mW Ventilation: 2W
<b>Further information</b>	
Cable for measurement	LiYCY 4 x 0.25mm <sup>2</sup> shielded, UV-resistant
Type of connection	Measuring electronics: Connector for data transmission and power supply Weather and thermal radiation shield: fixed 5m cable
Admissible environmental conditions	-20 ... +70 °C 0 ... 100 rel. humidity, including condensation
Dimensions	See 13. Dimensional drawing
Weight	Approx. 1,25kg
Type of protection	IP53
Housing material	Stainless steel, polycarbonate

1)  $\tau_{63\%}$

2) Derived from the accuracies of humidity and air temperature.

## 13 Dimensional Drawing

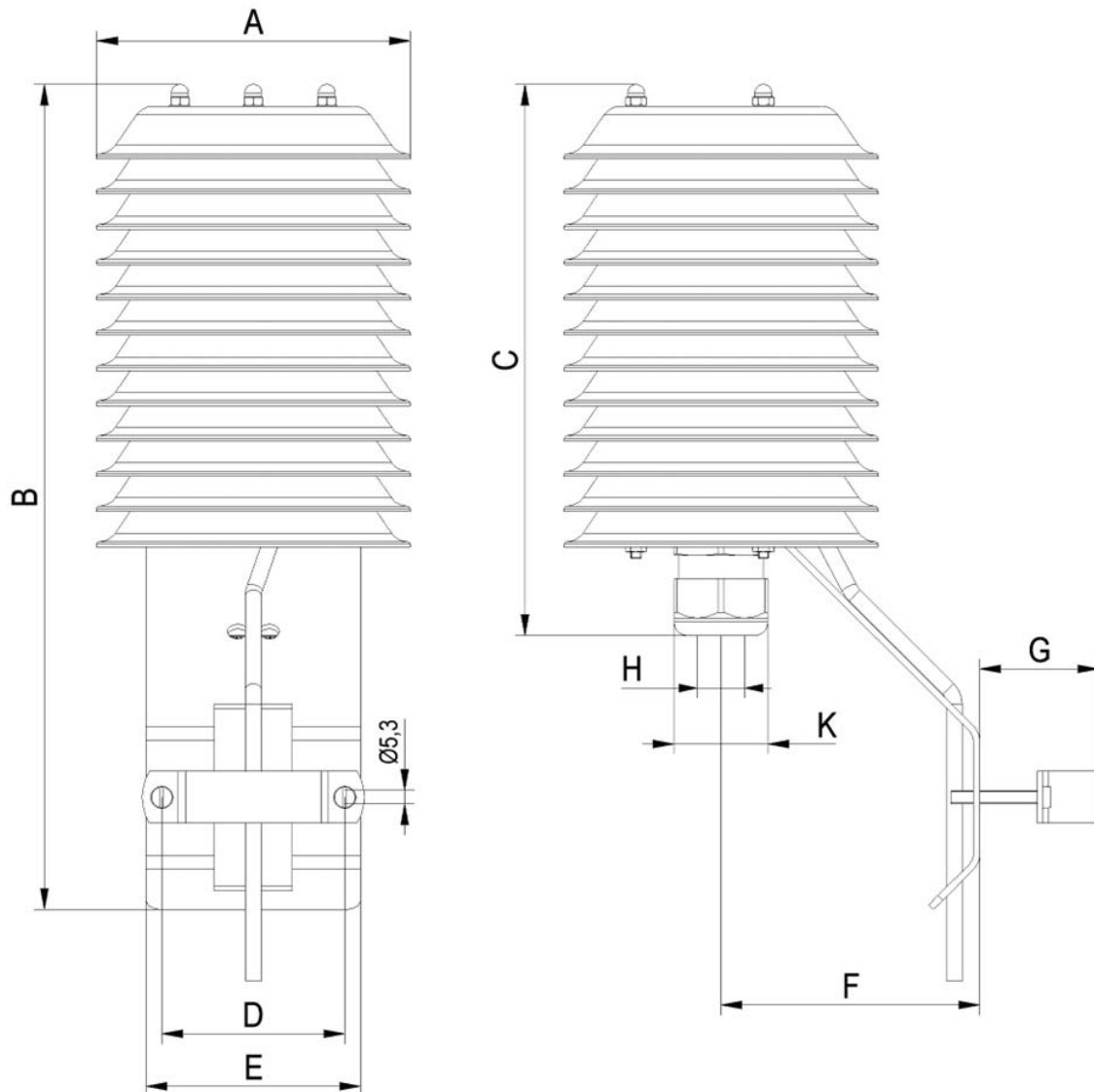

	A [mm]	B [mm]	C [mm]	D [mm]	E [mm]	F [mm]	G [mm]	H <sup>1</sup> [mm]	K <sup>2</sup> [KS]
1.1007.54.78x	Ø120	317	222	70	82	99	Ø35-50	Ø15-21	36

<sup>1)</sup> H = Sensor diameter; <sup>2)</sup> KS = Key size

## 14 Accessories (optional)

<b>Connection cable</b>	510641	For measurement electronics particulate-hygro-thermo-baro sensor compact. 5m, 4 x 0,25mm <sup>2</sup> Shielded, UV- and seawater resistant
<b>Replacement hygro-thermo measuring element</b>	510307	Calibrated replacement measuring element for exchange
<b>Sinter-filter-Cap</b>  The filter serves for protecting the sensor elements of the Hygro-thermo sensor against dust in case of field application	510314	Material: Stainless steel Dimensions: Ø 20 x 25mm.
<b>Protective cap</b>  The protective cap is used to protect the measuring elements of the Hygro-Thermo-BaroSensor from damage.	510488	Material: Plastic - POM
<b>Wall bracket ZA50</b>	1.1005.54.903	for Hygro-Thermo-Baro Sensor

Please contact us for other accessories such as cables, power supply units, masts, as well as for additional mast- or system-constructions.

## 15 Appendix

---

### 15.1 Calibration of the Sensor

It is possible to calibrate the sensor for the measured values Temperature, Rel. humidity and Air pressure. The individual steps for calibration are described below in the following points. Telegram 6 should be used to calibrate the sensor. The calibration result is not saved on the sensor. Any adjustment does not form part of the calibration process.

### 15.2 Calibration of Temperature / Humidity

The calibration of humidity and air temperature corresponds to the calibration of conventional sensors.

We recommend the following procedure for humidity calibration:

1. Storage of the device for several hours at rather low humidity levels
2. Carrying out the calibration in accordance with DKD guideline 5-8 "Calibration of hygrometers for direct measurement of relative humidity"; Procedure A1, A2, B1 or B2
3. Consideration of the adjustment time also according to the DKD guideline 5-8 "Calibration of hygrometers for the direct recording of the relative humidity"

To prevent confusion, the hygro-thermo measuring element must be set parameter CF 1 after calibrating. This ensures that on exchange of the hygro-thermo sensor element the air temperature / humidity is no longer output.

### 15.3 Calibration of Air Pressure

To calibrate the internal air pressure sensor, the entire device is exposed to the reference air pressure in a chamber. The air pressure sensor can be calibrated while observing the adjustment time.

## 15.4 Table and Figures Overview

### Table overview:

Table 1: Particulate matter measurement quality indicator .....	7
Table 2: Plug assignment of the sensor 1.1007.54.78x .....	9
Table 3: Status Word.....	18
Table 4: List of commands .....	18
Table 5: MODBUS Frame .....	32
Table 6: MODBUS Exceptions .....	32
Table 7: MODBUS Input Register.....	35
Table 8: Measured value telegram 1 .....	37
Table 9: Measured value telegram 2 .....	37
Table 10: Measured value telegram 3 .....	39
Table 11: Measured value telegram 4 .....	40
Table 12: Measured value telegram 6 .....	42

### Figures overview:

Figure 1: Example Pressure Equalization.....	6
Figure 2: Ventilation connection diagram.....	12
Figure 3: Connection of the status output .....	12
Figure 4: Ventilation status output values .....	12
Figure 5: Hygro-thermo Measuring Element.....	13

# 16 EC-Declaration of Conformity

**Manufacturer:** Adolf Thies GmbH & Co. KG  
 Hauptstraße 76  
 37083 Göttingen, Germany  
<http://www.thiesclima.com>

**Product:** FineDust-Hygro-Thermo-Baro Sensor Compact Doc. Nr. 2019-45076\_CE

**Article Overview:**  
 1.1007.54.780      1.1007.54.781

**The indicated products correspond to the essential requirement of the following European Directives and Regulations:**

2014/30/EU	26.02.2014	DIRECTIVE 2014/30/EU OF THE EUROPEAN PARLIAMENT AND OF THE COUNCIL of 26 February 2014 on the harmonisation of the laws of the Member States relating to electromagnetic compatibility.
2017/2102/EU	15.11.2017	DIRECTIVE (EU) 2017/2102 of the European Parliament and of the Council of November 15, 2017 amending Directive 2011/65/ EU on the restriction of the use of certain hazardous substances in electrical and electronic equipment.
2012/19/EU	13.08.2012	DIRECTIVE 2012/19/EU OF THE EUROPEAN PARLIAMENT AND OF THE COUNCIL of 4 July 2012 on waste electrical and electronic equipment (WEEE).

**The indicated products comply with the regulations of the directives. This is proved by the compliance with the following standards:**

DIN EN 55011+A1:2017	2018-05	Industrial, scientific and medical equipment - Radio-frequency disturbance characteristics - Limits and methods of measurement (CISPR 11:2015, modified + A1:2017); German version EN 55011:2016 + A1:2017
DIN EN 55016-2-3	2020-11	Specification for radio disturbance and immunity measuring apparatus and methods - Part 2-3: Methods of measurement of disturbances and immunity - Radiated disturbance measurements (CISPR 16-2-3:2016 + A1:2019); German version EN 55016-2-3:2017 + A1:2019
DIN EN 55016-2-1	2019-11	Specification for radio disturbance and immunity measuring apparatus and methods - Part 2-1: Methods of measurement of disturbances and immunity - Conducted disturbance measurements (CISPR 16-2-1:2014 + A1:2017); German version EN 55016-2-1:2014 + A1:2017
DIN EN 61000-4-2	2009-12	Electromagnetic Compatibility (EMC) - Part 4-2: Testing and measuring procedures - Testing of immunity to static electricity discharge
DIN EN IEC 61000-4-3	2021-11	Electromagnetic compatibility (EMC) - Part 4-3: Test and measurement procedures - Testing of immunity to high-frequency electromagnetic fields
DIN EN 61000-4-4	2013-04	Electromagnetic compatibility (EMC) - Part 4-4: Test and measurement methods - Testing of immunity to fast transient electrical disturbances / burst
DIN EN 61000-4-5	2019-03	Electromagnetic compatibility (EMC) - Part 4-5: Test and measurement procedures - Testing of immunity to surge voltages
DIN EN 61000-4-6	2014-08	Electromagnetic compatibility (EMC) - Part 4-6: Test and measurement methods - Immunity to conducted disturbances, induced by high-frequency fields
DIN EN 61000-4-8	2010-11	Electromagnetic compatibility (EMC) - Part 4-8: Testing and measurement techniques - Power frequency magnetic field immunity test (IEC 61000-4-8:2009); German version EN 61000-4-8:2010
DIN EN IEC 61000-6-1	2019-11	Electromagnetic compatibility (EMC) - Part 6-1: Generic standards - Immunity standard for residential, commercial and light-industrial environments (IEC 61000-6-1:2016)
DIN EN 61000-6-3:2007 + A1:2011	2011-09	Electromagnetic compatibility (EMC). Generic standards. Emission standard for residential, commercial and light-industrial environments
DIN EN 61326-1	2013-07	Electrical equipment for measurement, control and laboratory use. EMC requirements. General requirements
DIN EN IEC 63000	2019-05	Technical documentation for the assessment of electrical and electronic products with respect to the restriction of hazardous substances.

Göttingen, 30.05.2023



General Manager - Dr. Christoph Peper



Development Manager - ppa. Jörg Peterleit

This declaration of conformity is issued under the sole responsibility of the manufacturer.

This declaration certifies the compliance with the mentioned directives, however does not include any warranty of characteristics.

Please pay attention to the security advises of the provided instructions for use.



# 17 UK-CA-Declaration of Conformity

**Manufacturer:** Adolf Thies GmbH & Co. KG  
 Hauptstraße 76  
 37083 Göttingen, Germany  
<http://www.thiesclima.com>

**Product:** FineDust-Hygro-Thermo-Baro Sensor Compact

Doc. Nr. 2019-45076\_CA

**Article Overview:**

1.1007.54.780    1.1007.54.781

The indicated products correspond to the essential requirement of the following Directives and Regulations:

1091	08.12.2016	The Electromagnetic Compatibility Regulations 2016
RoHS Regulations 2012	01.01.2021	The Restriction of the Use of Certain Hazardous Substances in Electrical and Electronic Equipment Regulations 2012
3113	01.01.2021	Regulations: waste electrical and electronic equipment (WEEE)

The indicated products comply with the regulations of the directives. This is proved by the compliance with the following standards:

BS EN 55011+A2:2016 00.01.1900	31.05.2016	Industrial, scientific and medical equipment. Radio-frequency disturbance characteristics. Limits and methods of measurement
BS EN 55016-2-1+A1:2014-07-31	31.07.2014	Specification for radio disturbance and immunity measuring apparatus and methods. Methods of measurement of disturbances and immunity. Conducted disturbance measurements
BS EN 61000-4-2	31.05.2009	Electromagnetic compatibility (EMC). Testing and measurement techniques. Electrostatic discharge immunity test
BS EN IEC 61000-4-3	04.11.2020	Electromagnetic compatibility (EMC). Testing and measurement techniques. Radiated, radio-frequency, electromagnetic field immunity test
BS EN 61000-4-4	30.11.2012	Electromagnetic compatibility (EMC). Testing and measurement techniques. Electrical fast transient/burst immunity test
BS EN 61000-4-5+A1	30.09.2014	Electromagnetic compatibility (EMC). Testing and measurement techniques. Surge immunity test
BS EN 61000-4-6	28.02.2014	Electromagnetic compatibility (EMC). Testing and measurement techniques. Immunity to conducted disturbances, induced by radio-frequency fields
BS EN 61000-4-8	30.04.2014	Electromagnetic compatibility (EMC). Testing and measurement techniques. Power frequency magnetic field immunity test
BS EN 61000-6-1	28.02.2007	Electromagnetic compatibility (EMC) - Generic standards - Immunity for residential, commercial and light-industrial environments
BS EN IEC 61000-6-3	30.03.2021	Electromagnetic compatibility (EMC). Generic standards. Emission standard for equipment in residential environments
BS EN IEC 61326-1	07.06.2021	Electrical equipment for measurement, control and laboratory use. EMC requirements. General requirements
BS EN IEC 63000	10.12.2018	Technical documentation for the assessment of electrical and electronic products with respect to the restriction of hazardous substances

Göttingen, 30.05.2023

Legally binding signature:



General Manager - Dr. Christoph Peper

Legally binding signature:



Development Manager - ppa. Jörg Petereit

This declaration of conformity is issued under the sole responsibility of the manufacturer.

This declaration certifies the compliance with the mentioned directives, however does not include any warranty of characteristics.

Please pay attention to the security advises of the provided instructions for use.

## 18 More Information / Documents as download

---

Further information can be found in the short instructions for use. These document and also the instruction for use are available for download under the following links.

Short instruction for use

[https://www.thiesclima.com/db/dnl/1.1007.54.78x\\_Part particulate\\_Hygro\\_Thermo\\_Baro\\_Compact\\_FirstSteps\\_eng](https://www.thiesclima.com/db/dnl/1.1007.54.78x_Part particulate_Hygro_Thermo_Baro_Compact_FirstSteps_eng)

Instruction for use

[https://www.thiesclima.com/db/dnl/1.1007.54.78x\\_Part particulate\\_Hygro\\_Thermo\\_Baro\\_Compact\\_eng.pdf](https://www.thiesclima.com/db/dnl/1.1007.54.78x_Part particulate_Hygro_Thermo_Baro_Compact_eng.pdf)



**Please contact us for your system requirements.  
We advise you gladly.**

**ADOLF THIES GMBH & CO. KG**

Meteorology and environmental metrology  
Hauptstraße 76 · 37083 Göttingen · Germany  
Phone +49 551 79001-0 · Fax +49 551 79001-65  
info@thiesclima.com



[www.thiesclima.com](http://www.thiesclima.com)